

Learning Rates and Future Cost of Power Plants with CO₂ Capture

Edward S. Rubin

Department of Engineering and Public Policy
Carnegie Mellon University
Pittsburgh, Pennsylvania

Presentation to the
IEA International Workshop on Technology Learning and Deployment
Paris, France
June 11, 2007

Acknowledgements

- *Collaborators:*
 - Matt Antes
 - Sonia Yeh
 - Mike Berkenpas
- *Advisors:*
 - Dale Simbeck
 - Howard Herzog
 - Jon Gibbins
 - Keywan Riahi
 - Leo Schrattenholzer
 - Rodney Allam
- *Sponsor:*
 - IEA GHG (John Davison)

Study Objective

- Develop an empirically-based method to estimate learning rates and future costs of power plants with CO₂ capture, suitable for use in energy modeling, R&D planning, and related activities

Use Powerful Analytical Methods



Two Approaches to Estimating Future Technology Costs

- Method 1: Engineering-Economic Modeling
 - A “bottom up” approach based on engineering process models, informed by expert elicitations regarding potential improvements in key process parameters
- Method 2: Use of Historical Experience Curves
 - A “top down” approach based on use of mathematical “learning curves” or “experience curves” reflecting historical trends for analogous technologies or systems

This study employs the latter method

Study Approach

- Quantify historical learning rates of energy and environmental technologies relevant to power plants with CO₂ capture
- Apply these results to leading plant design options to estimate learning rates and future plant costs

Note: This study does not include the costs of CO₂ transport and storage technologies

- Detailed report available from International Energy Agency Greenhouse Gas Programme (IEA GHG)
- Summary paper available in *IJGGC*, 2007

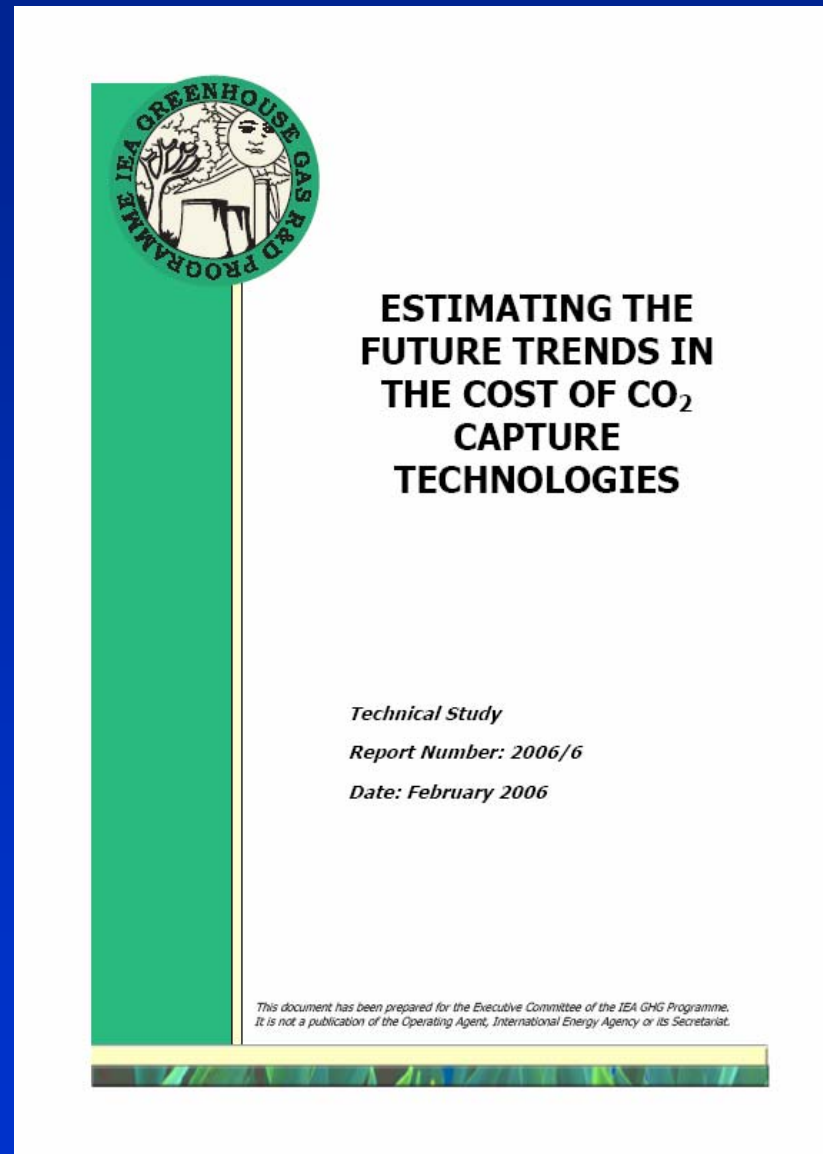

Retrospective Case Studies

Case Study Technologies

- Flue gas desulfurization systems (FGD)
- Selective catalytic reduction systems (SCR)
- Gas turbine combined cycle system (GTCC)
- Pulverized coal-fired boilers (PC)
- Liquefied natural gas plants (LNG)
- Oxygen production plants (ASU)
- Hydrogen production plants (SMR)

Learning Curve Formulation

General equation:

$$y_i = ax_i^{-b}$$

where,

y_i = time or cost to produce i^{th} unit

x_i = cumulative production thru period i

b = learning rate exponent

a = coefficient (constant)

Percent cost reduction for a doubling of cumulative output is called the “learning rate” $(LR) = (1 - 2^{-b})$

FGD System Capital Costs

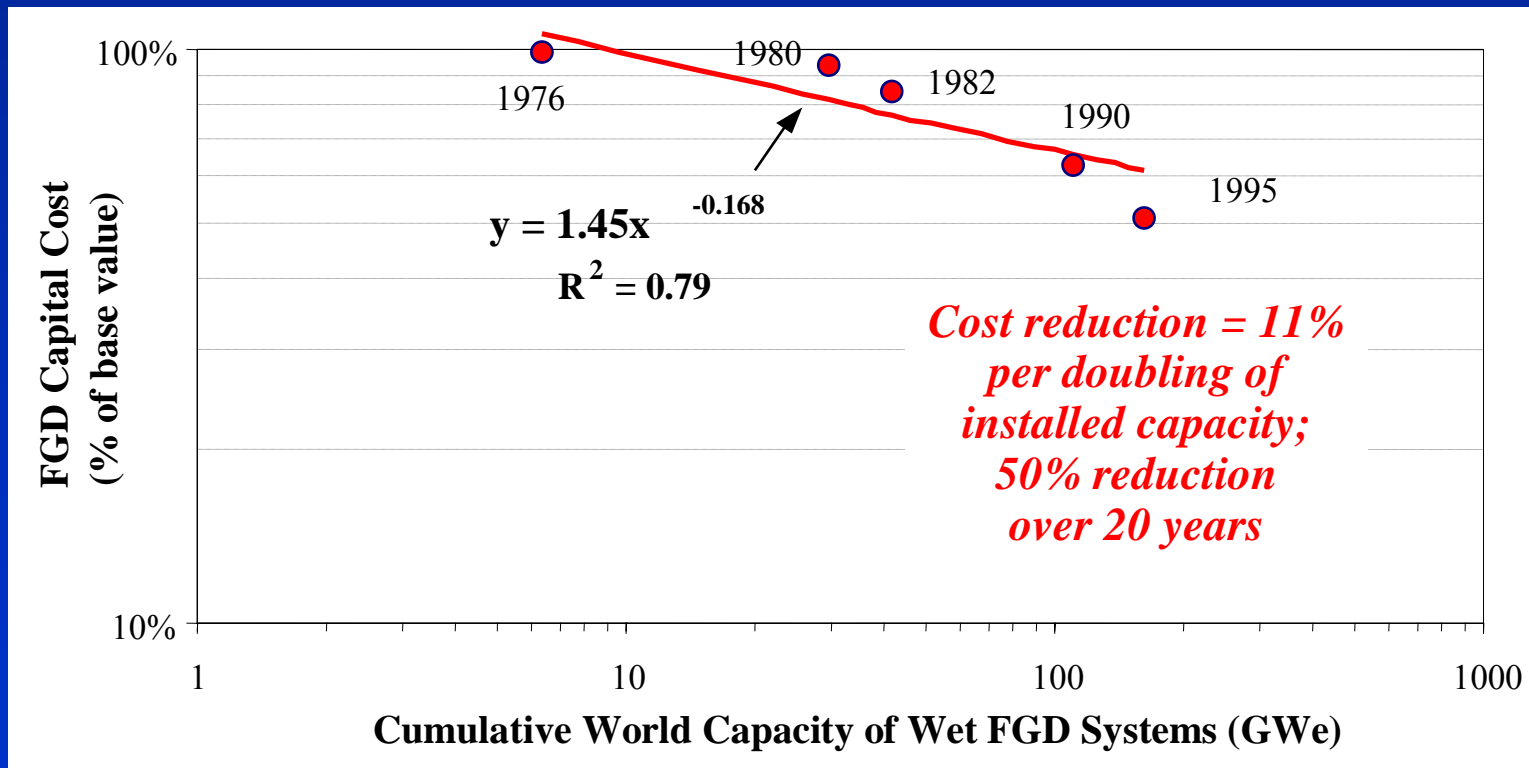

(Based on 90% SO₂ removal, 500 MW plant, 3.5% S coal)

SCR System Capital Costs

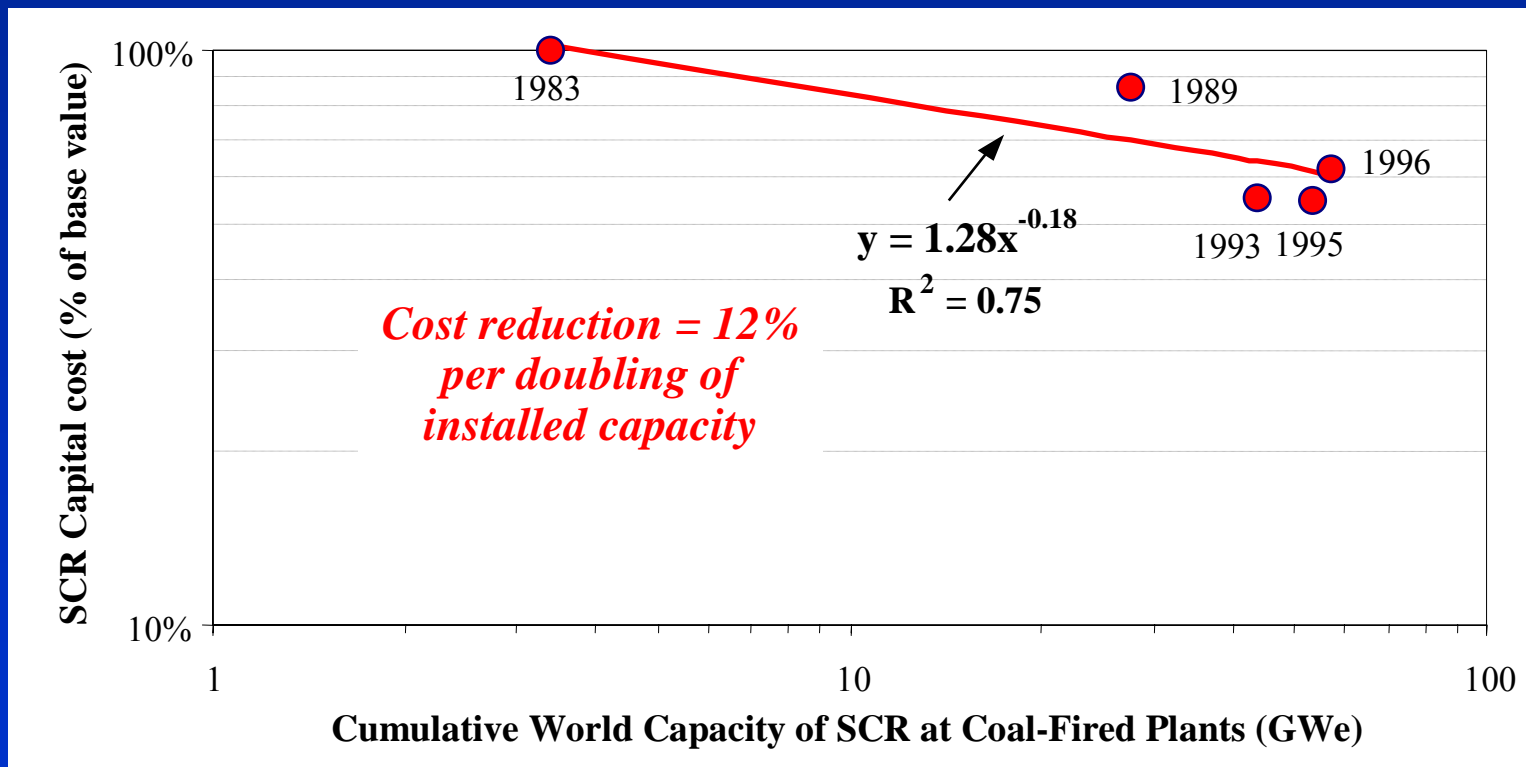

(Based on 80% NO_x removal, 500 MW plant, medium S coal)

Early Trend of FGD Capital Cost

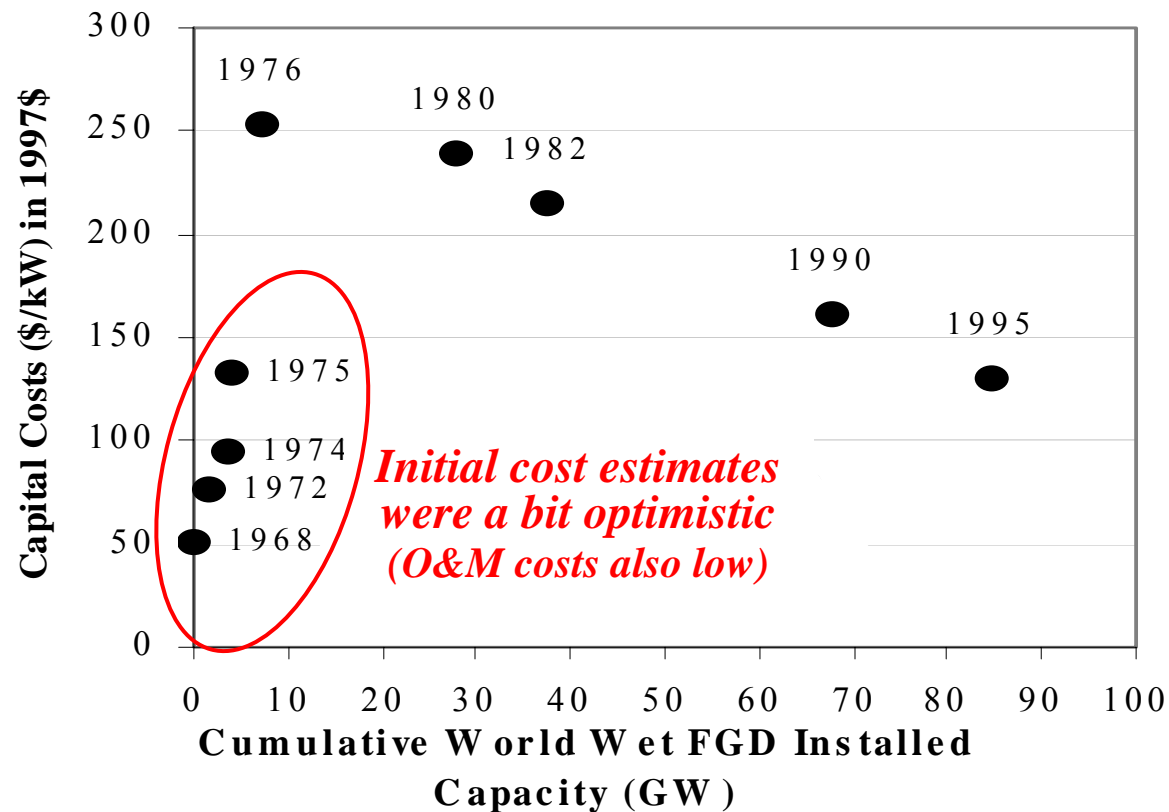

Early Trend of SCR Cost Estimates

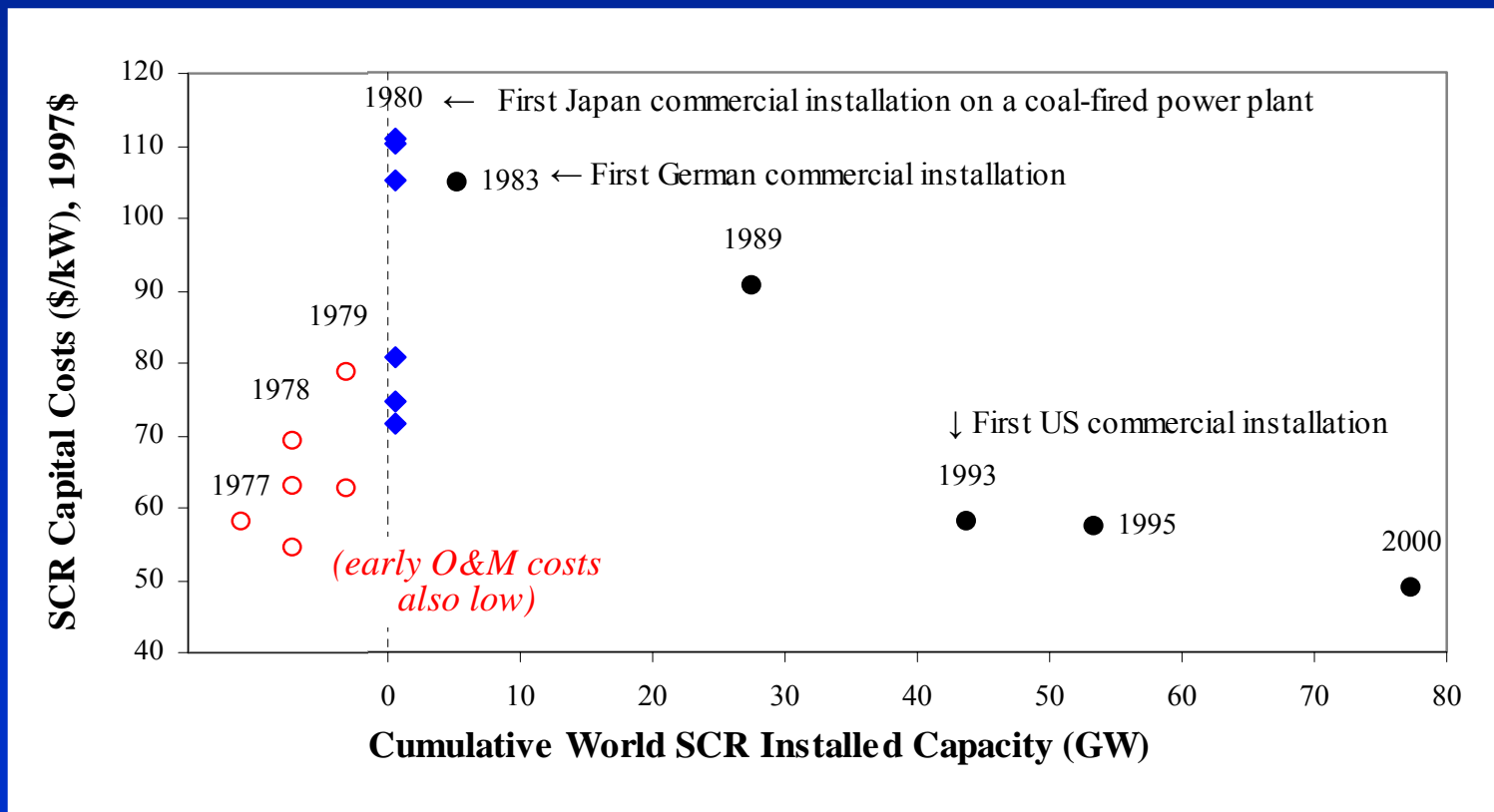

GTCC Capital Costs

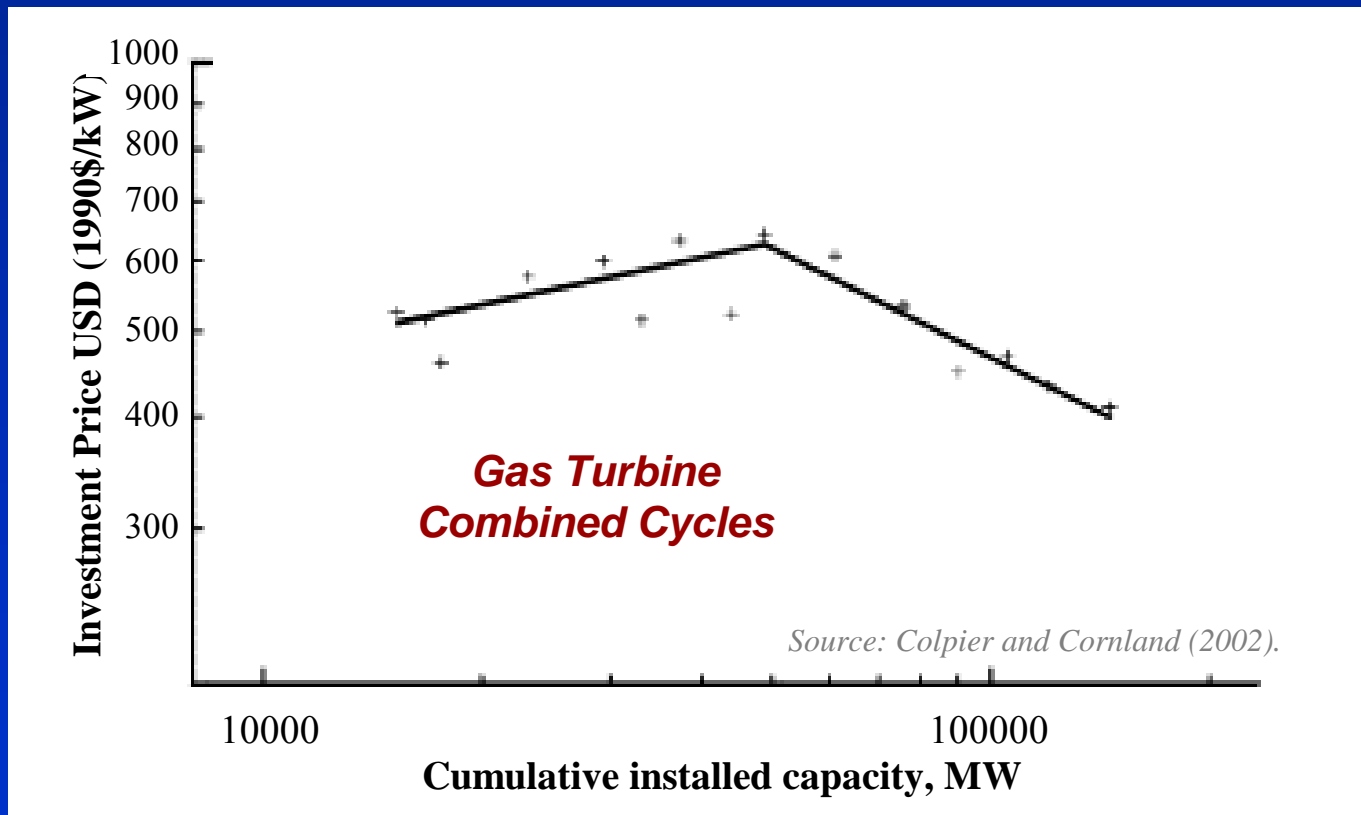

LNG Plant Capital Costs

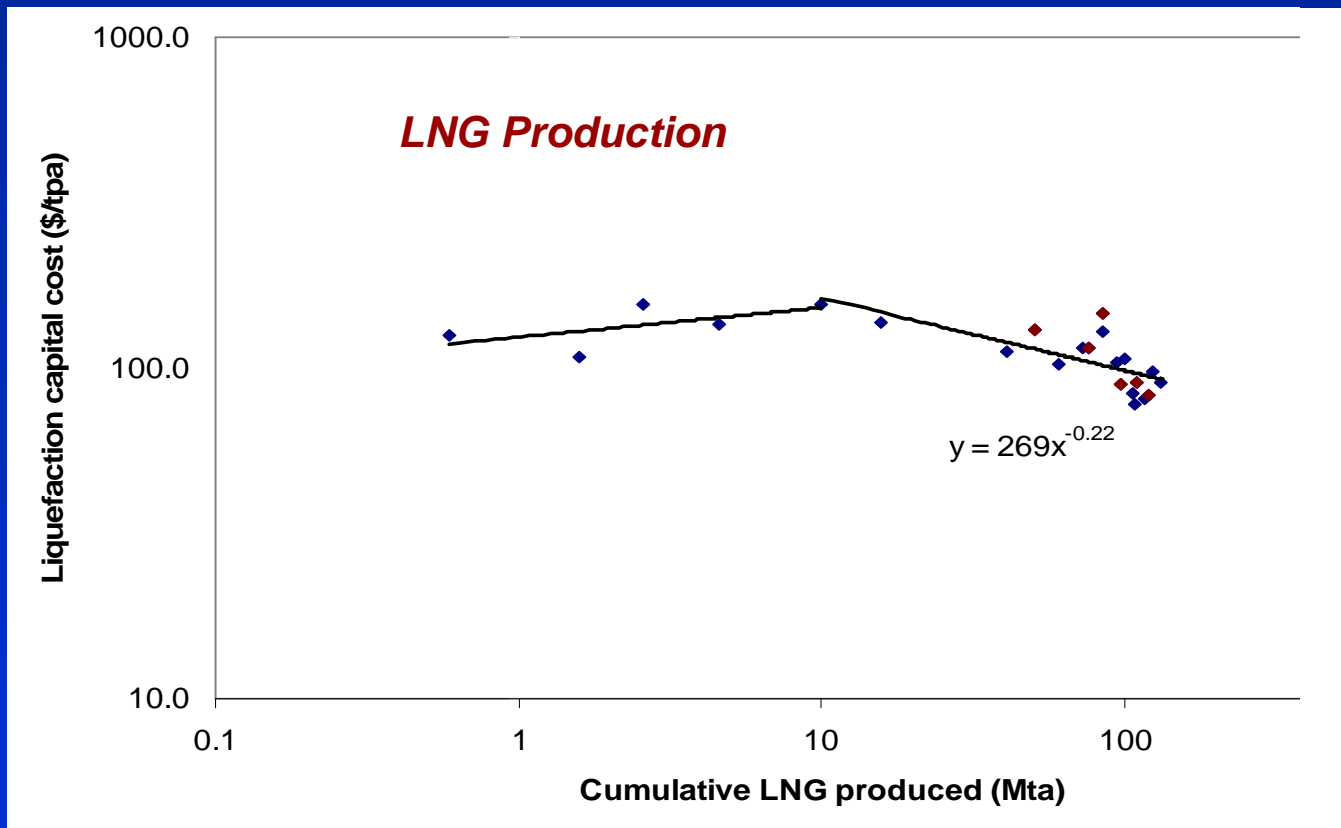

PC Boiler Capital Costs

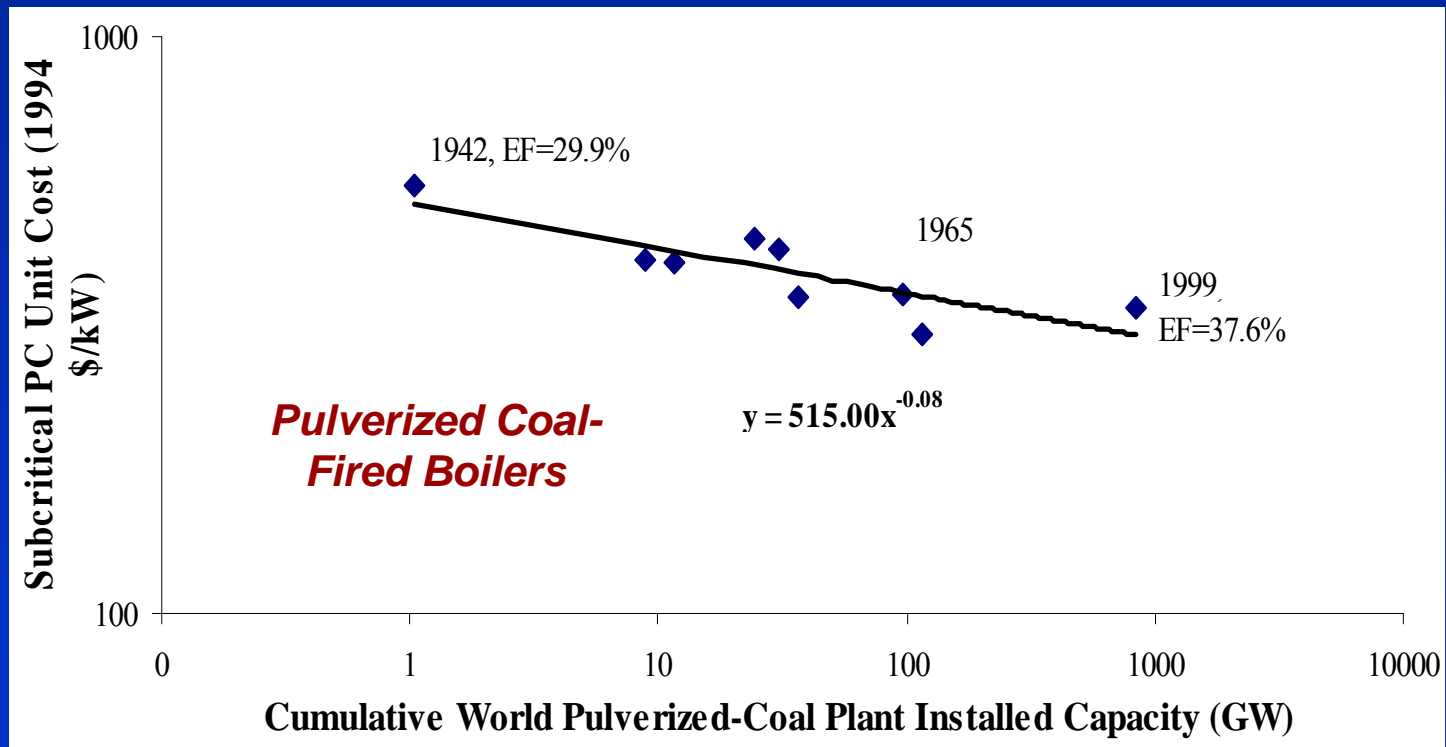

Oxygen Plant Capital Cost

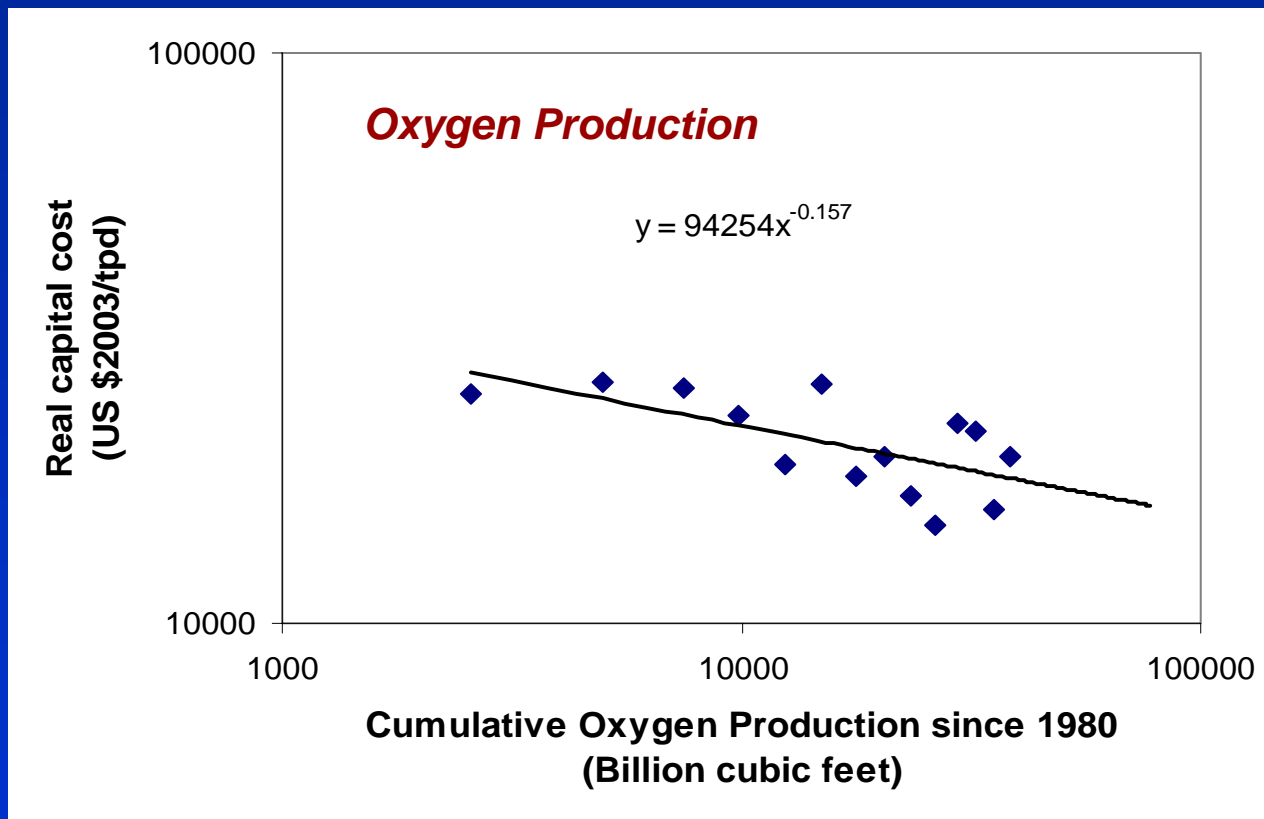

Case Study Learning Rates

Technology	“Best Estimate” Learning Rates	
	Capital Cost	O&M Cost
Flue gas desulfurization (FGD)	0.11	0.22
Selective catalytic reduction (SCR)	0.12	0.13
Gas turbine combined cycle (GTCC)	0.10	0.06
Pulverized coal (PC) boilers	0.05	0.18
LNG production	0.14	0.12
Oxygen production (ASU)	0.10	0.05
Hydrogen production (SMR)	0.27	0.27

Results are within ranges reported for other energy-related technologies

*Application to Power Plants
with CO₂ Capture*

Power Plants with CO₂ Capture

- PC plant with post-combustion capture (amine system)
- PC plant with oxyfuel combustion
- NGCC plant with post-combustion capture (amine system)
- IGCC coal plant with pre-combustion capture (WGS + Selexol)

Baseline Plant Designs (1)

PC Plant

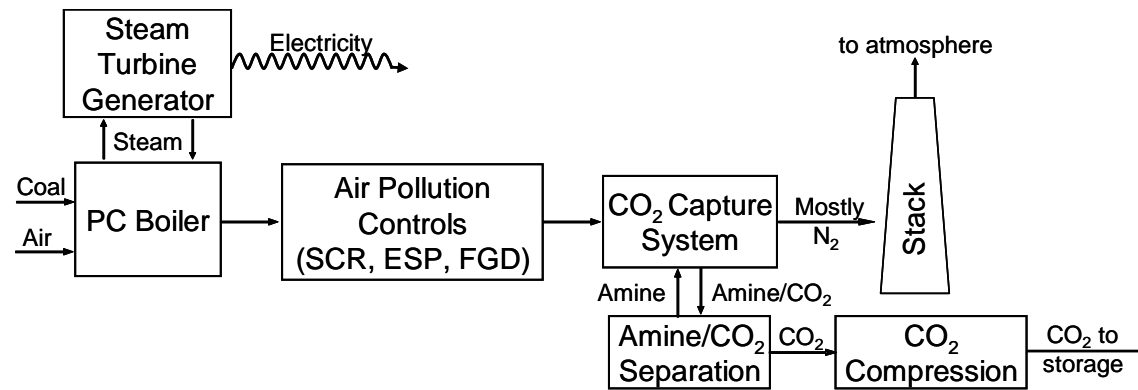

Oxyfuel Plant

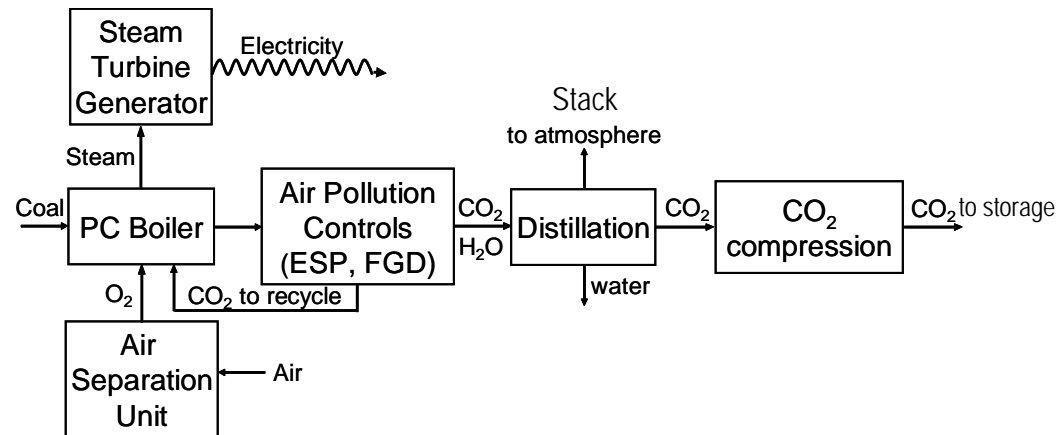

Baseline Plant Designs (2)

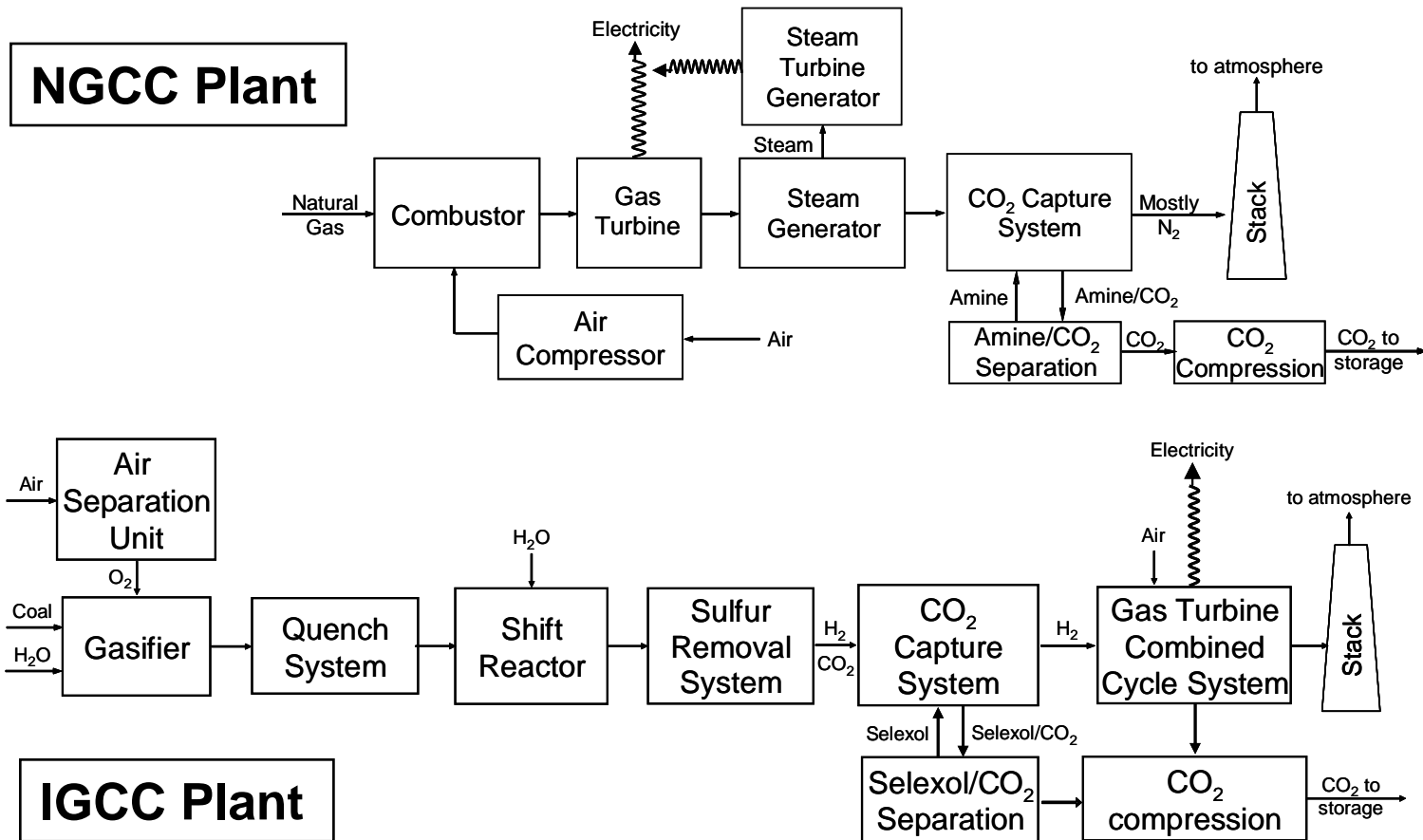

Step 1: Disaggregate each plant into major sub-sections

For example:

- IGCC Plant Components
 - Air separation unit
 - Gasifier area
 - Sulfur removal/recovery system
 - CO₂ capture system (WGS+Selexol)
 - CO₂ compression
 - GTCC (power block)
 - Fuel cost

Step 2: Estimate current plant costs and contribution of each sub-section

Levelized costs in constant \$2002

Plant Type & Technology	Capital Cost	Annual O&M Cost*	Cost of Electricity*
IGCC Plant w/ Capture	1,831 \$/kW	21.3 \$/MWh	62.6 \$/MWh
Air separation unit	18 %	8 %	14 %
Gasifier area	27 %	17 %	24 %
Sulfur removal/recovery	6 %	3 %	5 %
CO ₂ capture system*	13 %	7 %	11 %
CO ₂ compression	2%	2 %	2 %
GTCC (power block)	34 %	9 %	25 %
Fuel cost**	--	54%	19 %

*Excludes costs of CO₂ transport and storage **Based on Pittsburgh #8 coal @ \$1.0/GJ

Baseline costs obtained from IECM

- A computer model developed for DOE/NETL, benchmarked on recent engineering studies
- Provides preliminary design estimates of performance, emissions and cost for:
 - PC, NGCC and IGCC plants
 - Conventional AP controls
 - CCS options (pre- and post-combustion, oxyfuel comb.)
- Free Web Download :
 - www.iecm-online.com

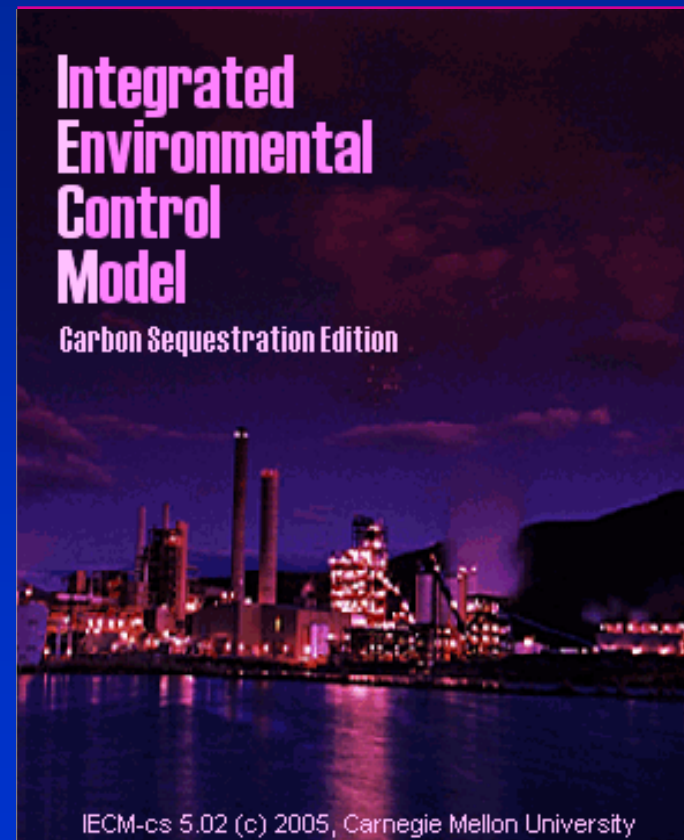

Step 3: Select learning rate analogues for each plant component

Plant Type & Technology	FGD	SCR	GTCC	PC boiler	LNG prod	O ₂ prod
IGCC Plant						
Air separation unit						X
Gasifier area					X	
Sulfur removal/recovery	X	X				
CO ₂ capture system	X	X				
CO ₂ compression						
GTCC (power block)			X			

Step 4: Estimate current capacity of major plant components

Plant Type & Technology	Current MW_{net} Equiv.
IGCC Plant Components	
Air separation units	50,000
Gasifier area	10,000
Sulfur removal/recovery	50,000
CO ₂ capture system	10,000
CO ₂ compression	10,000
GTCC (power block)	240,000

Step 5: Set projection period and start of learning

Plant Type	Cumulative CCS Capacity (MW)		
	<u>Learning Begins at:</u>		Learning Projected to:
	1 st Plant	n th Plant	
NGCC Plant	432	3,000	100,000
PC Plant	500	5,000	100,000
IGCC Plant	490	7,000	100,000
Oxyfuel Plant	500	10,000	100,000

Step 6: Sensitivity Analysis

- Learning starts at either first or n^{th} plant
- Range of component learning rates
- Projection to 50 GW of worldwide capacity
- Lower estimates of current component capacity
- Effect of additional non-CCS experience
- Higher fuel prices for coal and natural gas
- Lower financing costs + higher plant utilization

results
are
available
in full
report
and
journal
paper

NGCC Sensitivity Case	Capital Cost (\$/kW)				COE (\$/MWh)			
	Learning Rate	Initial Value	Final Value	% Change	Learning Rate	Initial Value	Final Value	% Change
Nominal Base Case Assumptions	0.022	916	817	10.8%	0.033	59.1	49.9	15.5%
Learning Starts with First Plant	0.014	916	811	11.5%	0.028	59.1	47.0	20.4%
Learning up to 50 GW	0.018	916	849	7.3%	0.031	59.1	52.0	12.0%
Current Capture Capacity = 0 GW	0.029	916	786	14.2%	0.037	59.1	48.8	17.4%
Non-CSS Exp. Multipliers = 2.0	0.030	916	783	14.4%	0.036	59.1	49.0	17.1%
Natural Gas Price = \$6.0/GJ	0.022	925	826	10.7%	0.033	76.1	64.2	15.7%
FCF = 11%, CF = 85%	0.022	918	820	10.7%	0.034	51.6	43.3	16.1%

PC Sensitivity Case	Capital Cost (\$/kW)				COE (\$/MWh)			
	Learning Rate	Initial Value	Final Value	% Change	Learning Rate	Initial Value	Final Value	% Change
Nominal Base Case Assumptions	0.021	1,962	1,783	9.1%	0.035	73.4	62.8	14.4%
Learning Starts with First Plant	0.013	1,962	1,764	10.1%	0.024	73.4	60.8	17.2%
Learning up to 50 GW	0.018	1,962	1,846	5.9%	0.031	73.4	66.0	10.1%
Current Capture Capacity = 0 GW	0.026	1,962	1,744	11.1%	0.042	73.4	60.9	17.1%
Non-CSS Exp. Multipliers = 2.0	0.029	1,962	1,723	12.2%	0.068	73.4	60.4	17.8%
Coal Price = \$1.5/GJ	0.021	1,965	1,786	9.1%	0.035	79.6	68.2	14.3%
FCF = 11%, CF = 85%	0.021	1,963	1,785	9.1%	0.039	57.2	48.2	15.7%

IGCC Sensitivity Case	Capital Cost (\$/kW)				COE (\$/MWh)			
	Learning Rate	Initial Value	Final Value	% Change	Learning Rate	Initial Value	Final Value	% Change
Nominal Base Case Assumptions	0.050	1,831	1,505	17.8%	0.049	62.6	51.5	17.7%
Learning Starts with First Plant	0.029	1,831	1,448	20.9%	0.032	62.6	48.6	22.4%
Learning up to 50 GW	0.044	1,831	1,610	12.1%	0.045	62.6	54.9	12.2%
Current Gasifier Capacity = 1 GW	0.057	1,831	1,460	20.3%	0.055	62.6	50.2	19.7%
Above + H2-GTCC = 0 GW	0.088	1,831	1,285	29.8%	0.078	62.6	45.9	26.6%
Non-CSS Exp. Multipliers = 2.0	0.062	1,831	1,432	21.8%	0.054	62.6	49.5	20.8%
Coal Price = \$1.5/GJ	0.050	1,834	1,507	17.8%	0.048	68.4	56.6	17.3%
FCF = 11%, CF = 85%	0.048	1,832	1,516	17.2%	0.047	47.2	39.2	16.9%

Oxyfuel Sensitivity Case	Capital Cost (\$/kW)				COE (\$/MWh)			
	Learning Rate	Initial Value	Final Value	% Change	Learning Rate	Initial Value	Final Value	% Change
Nominal Base Case Assumptions	0.028	2,417	2,201	9.0%	0.030	78.8	71.2	9.6%
Learning Starts with First Plant	0.013	2,417	2,160	10.7%	0.017	78.8	68.6	12.9%
Learning up to 50 GW	0.023	2,417	2,291	5.2%	0.025	78.8	74.3	5.8%
Current Boiler Capacity = 0	0.054	2,417	2,008	16.9%	0.056	78.8	65.1	17.5%
Non-CSS Exp. Multipliers = 2.0	0.038	2,417	2,122	12.2%	0.044	78.8	68.8	12.7%
Coal Price = \$1.5/GJ	0.028	2,421	2,204	9.0%	0.030	84.7	76.4	9.8%
FCF = 11%, CF = 85%	0.028	2,418	2,202	9.0%	0.031	58.8	53.0	9.9%

Results for IGCC Capital Cost

(Assume learning begins at first capture plant)

Based on nominal case study assumptions

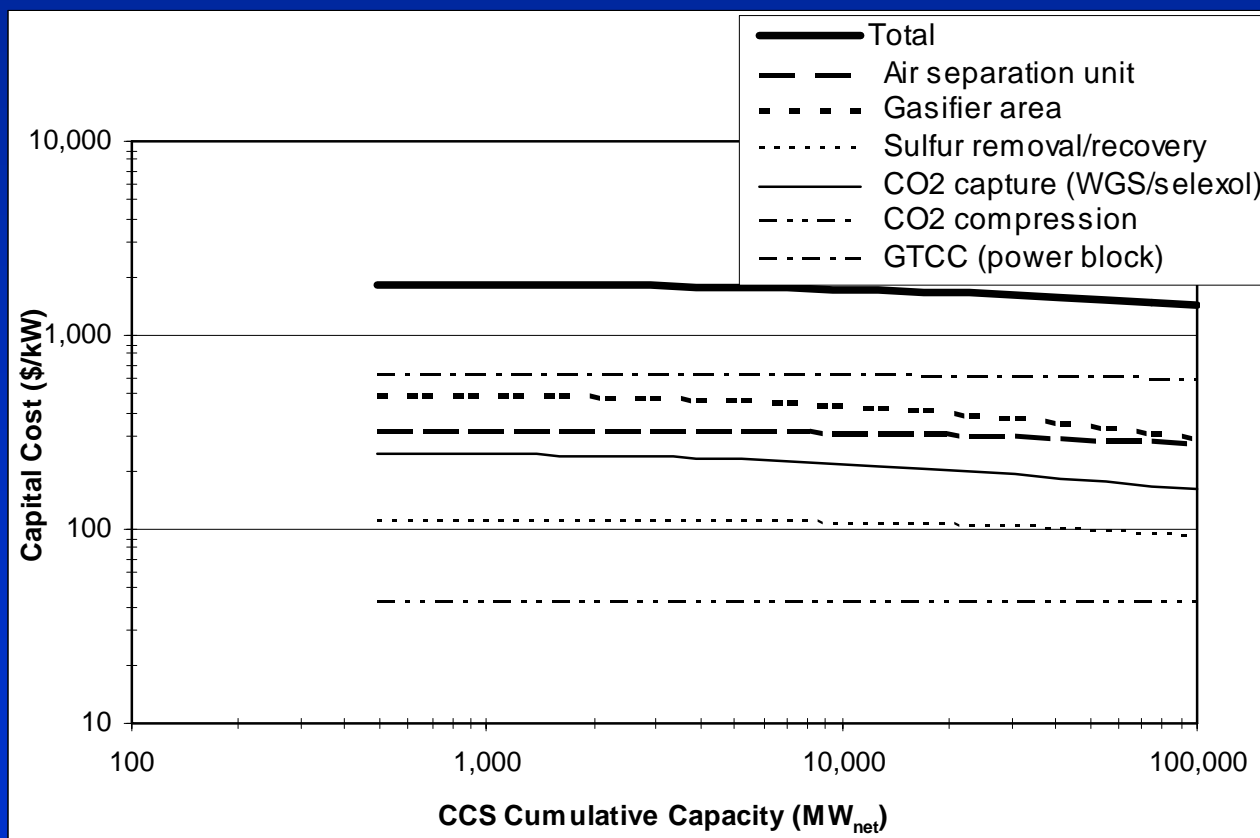

Summary of Learning Rate Results

(Based on 100 GW of cumulative CCS capacity)

CAPITAL COST

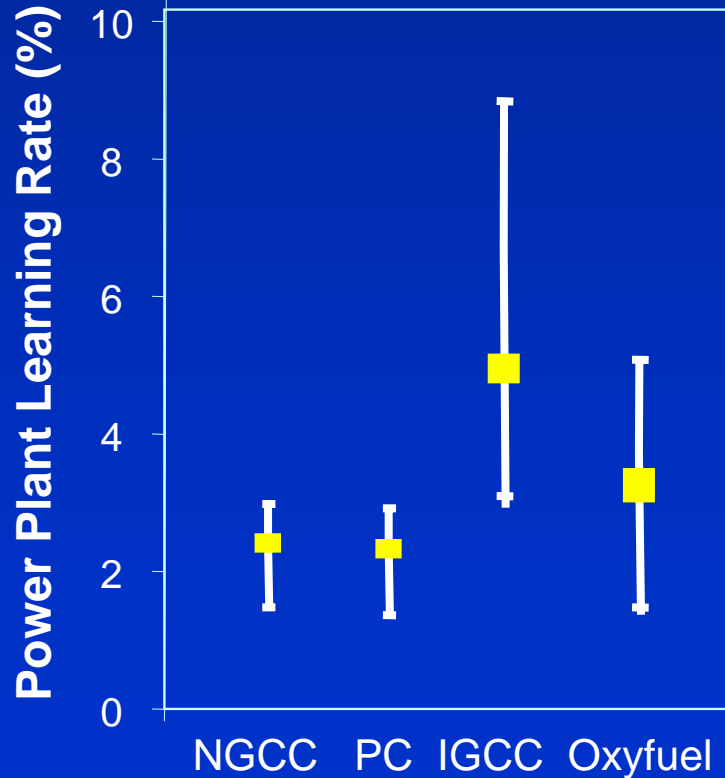

COST OF ELECTRICITY

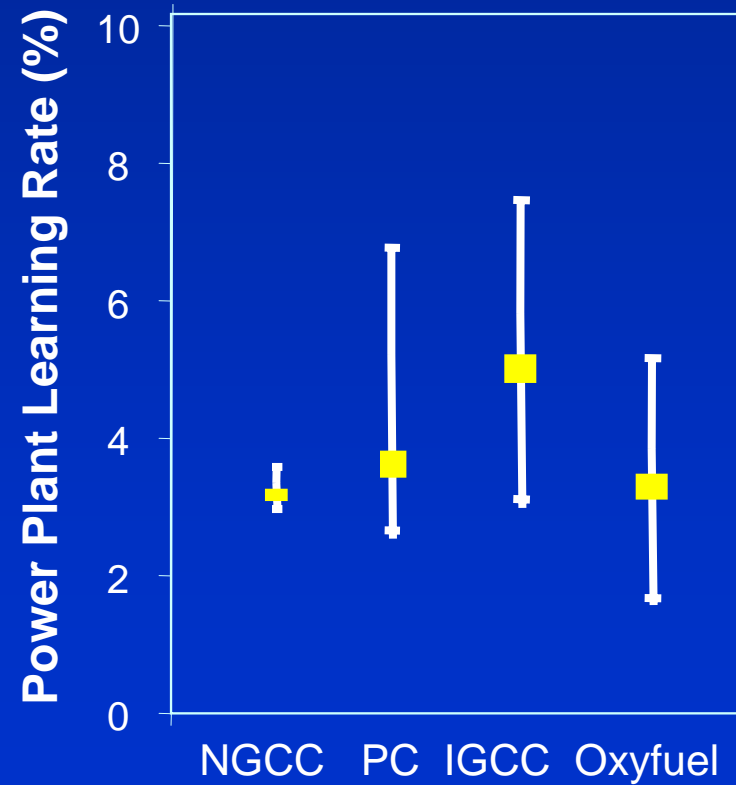

Summary of COE Results

(Based on 100 GW of cumulative CCS capacity)

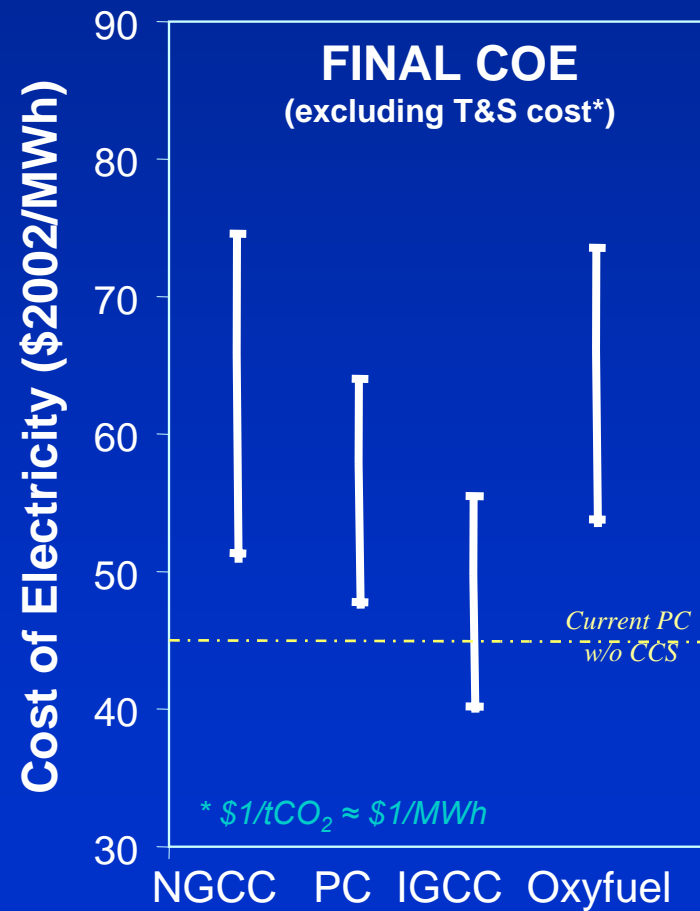
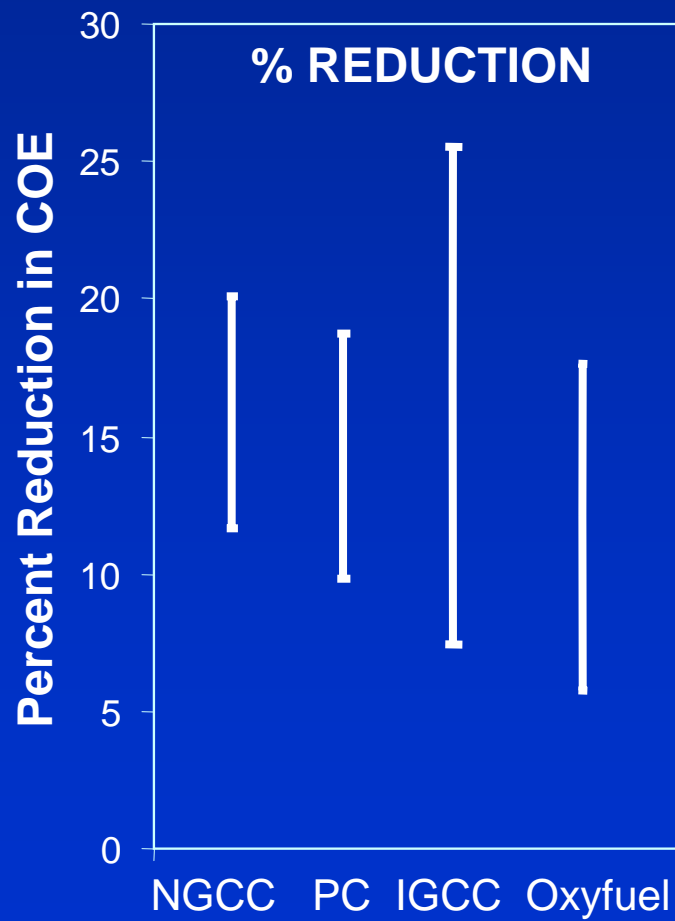

Percentage Reduction in Overall Cost of CO₂ Capture

(Based on 100 GW of cumulative CCS capacity)

Technology	Capital Cost	Cost of Capture
NGCC, post-comb	20	40
PC, post-comb	15	26
IGCC, pre-comb	15	20
Oxyfuel comb	13	13

Capture cost is the difference between plants with and without capture at any point in time. This cost falls more rapidly than the total cost of plants with capture.

Caveats

- There are many!
- Please see full report for details.
 - *A spreadsheet model also is available to facilitate analyses for other assumptions*

Thank You

rubin@cmu.edu